

INSTRUCTIONS FOR MODEL 970-M VACUUM PAN OVERSATURATION MONITOR

(for use with Serial #456 and higher, sold on or after 6/30/2015)



FOR PARTS AND INFORMATION CONTACT:

ZIEGLER & ASSOCIATES

11180 Ranchette Dr.

Jackson CA 95642

USA

PHONE 209-223-1090

FAX 209-223-1090

Email: info@zieglerassociates.com

Web: www.zieglerassociates.com

TABLE OF CONTENTS

NOTE: This manual is for use with Model 970-M Sugar Oversaturation Monitor & Probe serial #456 and higher. For lower serial numbers, please visit www.zieglerassociates.com to download the appropriate manual.

DESCRIPTION	3
PRINCIPLE OF OPERATION	3
INSTALLATION	3
REFERENCE WATER SUPPLY.....	4
Figure 1: Hot Water Supply.....	4
MOUNTING THE MONITOR.....	5
Environment:.....	5
Figure 2: Monitor Mounting Dimensions.....	5
Figure 3: NEMA 4X Enclosure Dimensions.....	6
Figure 4: Connecting Measuring Element and Monitor.....	7
DC Power Connections.....	7
Sensor Connections.....	8
Setting Jumpers for 120VAC or 240VAC.....	8
Output Connections/Settings.....	8
START UP	8
PRECISE ZERO SETTING.....	9
MICROSCOPES.....	10
BOILING WITH THE 970-M OVERSATURATION MONITOR	10
BRINGING TOGETHER.....	11
FINAL TIGHTENING.....	11
CRYSTAL YIELD.....	13
POSSIBLE MEASUREMENT ERRORS	13
Figure 5: Locating the Sensor Element on Pans with Cast Iron Domes and Separators.....	15
Figure 6: Installing a Low Dam in the Vapor Line.....	17
FEED DISTRIBUTION.....	18
TECHNICAL INFORMATION	19
ELECTRICAL TESTS.....	19
SENSOR/MEASURING ELEMENT.....	19
Sensor Dimensions.....	19
Sensor Parts.....	20
ELECTRONIC TRANSMITTER.....	20
Circuit Board Component Layout.....	20
Circuit Diagram (AC Power).....	21
Circuit Diagram (DC Power).....	22
WARRANTY	23

DESCRIPTION

The Model 970-M Monitor is designed to indicate the Oversaturation of sugar syrups boiling in Vacuum Pans. It is adjustable for cane and beet syrups over the range of purities normally encountered in sugar boiling and is compensated for absolute pressure variations between 4 and 10 In.Hg.Abs (10 to 25 Cm.Hg.Abs.) The range is from 0 to 100% Oversaturation (1.0 to 2.0 Supersaturation).

Once adjusted for the syrup being boiled, the reading will be 65% at the upper limit of the metastable zone; below this value, sugar crystals will grow in an orderly manner at a rate very nearly proportional to the Oversaturation. A higher concentration takes the syrup into the labile zone where false or spurious grain is produced.

PRINCIPLE OF OPERATION

The measuring element consists of two matched resistance thermometer bulbs in a compact assembly. One bulb responds to the temperature of pan vapor that should be the same as that at the surface of the boiling massecuite. There can be temperature gradients within the pan but at the surface, there is no hydrostatic head so the lowest temperature, and consequently highest oversaturation will exist there. The other bulb measures the temperature of hot water flashing down to the existing equilibrium vapor pressure. The two bulb readings are computed by the Monitor circuitry to give a direct reading of syrup oversaturation.

By holding oversaturation at optimum values during each pan cycle, it is possible to repeatedly produce well-formed crystals and high pan yields, reducing the amount of syrup that must be reboiled and improving molasses exhaustion.

INSTALLATION

Before installing, check the pan thoroughly to be sure that it is free from any obvious deficiencies, and read "Possible Measurement Errors" starting on page 12. This section will also help in selecting the best location for the measuring element on a particular pan.

Weld a 1-1/4" NPT pipe coupling on the entrainment separator or pan vapor line (or tap the hole 1-1/4" NPT in the case of cast iron construction) to receive the measuring element. It may be horizontal or slope upward for greater installation convenience, but a downward slope should be avoided because it is possible for flashing water droplets to run down to the last 2" sensitive portion of the vapor bulb and cool it. Measure the internal clearance to be sure that the vapor bulb will not strike any obstruction that could demote it. Screw in the element, positioning it so that the 1" square window is on the downstream side relative to vapor flow; flashing water will then be swept away from the vapor bulb.

REFERENCE WATER SUPPLY

The flash chamber in which the reference bulb is located must be continuously fed with a small flow of clean hot water or condensate at a temperature higher than the maximum equilibrium vapor temperature. Even at 10" Hg. Abs., water at 75°C is satisfactory, but it does not matter if it is much hotter than this. The required flow is small, nominally about 5 GPH (300 ml/min.) but larger or smaller flows will not affect the monitor reading as long as it remains hot enough to flash when it gets to the measuring element. If a source of centrifugal wash or house hot water is not convenient to the pan floor, pan condensate can be readily used. If a connection is made in the bottom of the line carrying condensate from the pan heating surface, it will always be available whenever the pan is operating and at a higher temperature than the pan contents (see Figure 1 below).

Figure 1: Hot Water Supply

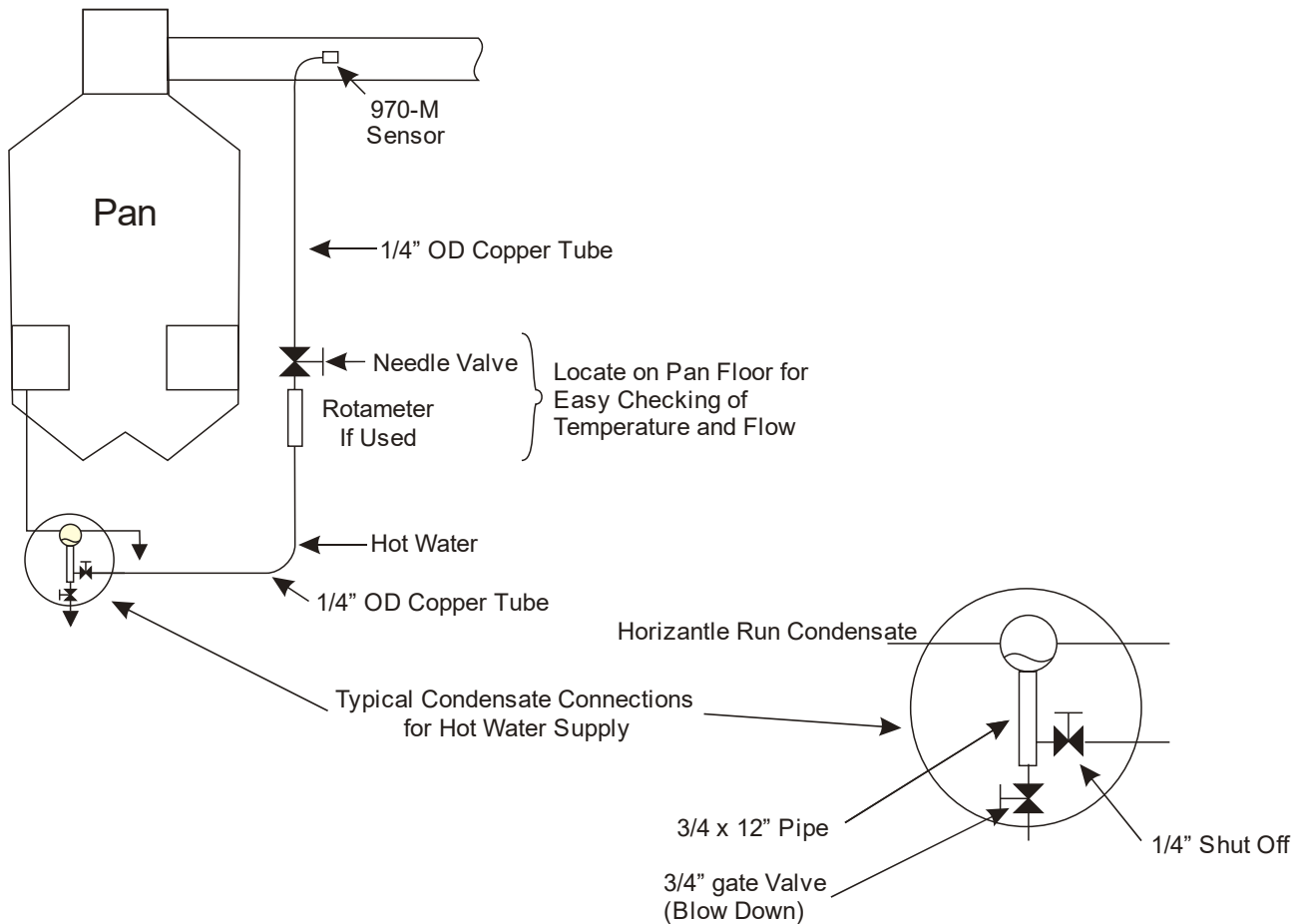

As noted, the water flow is not critical but if a rotameter or some similar flow measuring device is installed to monitor water flow, put the metering needle valve in the pan side of the water line to prevent flashing in the meter. A suitable needle valve such as Hoke #309, 1/4" V point needle is most satisfactory and will give adequate flow when opened around one quarter of a turn. At the flows required, 1/4" OD Copper tubing is adequate between the metering valve and the measuring element and if the water flashes downstream of the valve, it only hastens

delivery to the flash chamber and reduces the chance of cooling en-route. Excessive water flow could create a slight pressure in the flash chamber but the chances of this are very remote if 1/4" OD tubing is used for the water supply. An easy check is to increase and decrease water flow when readings are stable to see if any change in meter reading is observed.

An air leak between metering valve end measuring element will draw in air and change the partial pressure in the reference chamber, resulting in a higher oversaturation reading. Be sure that this line is leak free.

MOUNTING THE MONITOR

Mount the monitor so it is easily visible to the pan operator from manually operated syrup and water feed valves or consistency control instruments if they are being used. The instrument is normally flush-mounted, but can be face-mounted by using two stand-off brackets. Figure 2 below shows mounting dimensions for the panel/wall mount enclosure. Figure 3 on page 5 shows the optional NEMA 4X (watertight) enclosure mounting dimensions. Remove front panel and meter assembly (2 screws). Disconnect plug on circuit board and set the front panel aside. Mount case and circuit board assembly using the two holes in the case flange and the #6-32 flat head screws provided. If you are using the NEMA 4X enclosure, you can mount it to a wall using the 4 provided holes that are behind the plastic cover mounting screws.

Environment:

The panel/wall mount enclosure must be situated in a dry area. The NEMA 4X enclosure is suitable for wall or pipe mounting and relatively harsh or damp atmospheres. Ambient temperatures should be between 0°C and 50°C.

Figure 2: Monitor Mounting Dimensions

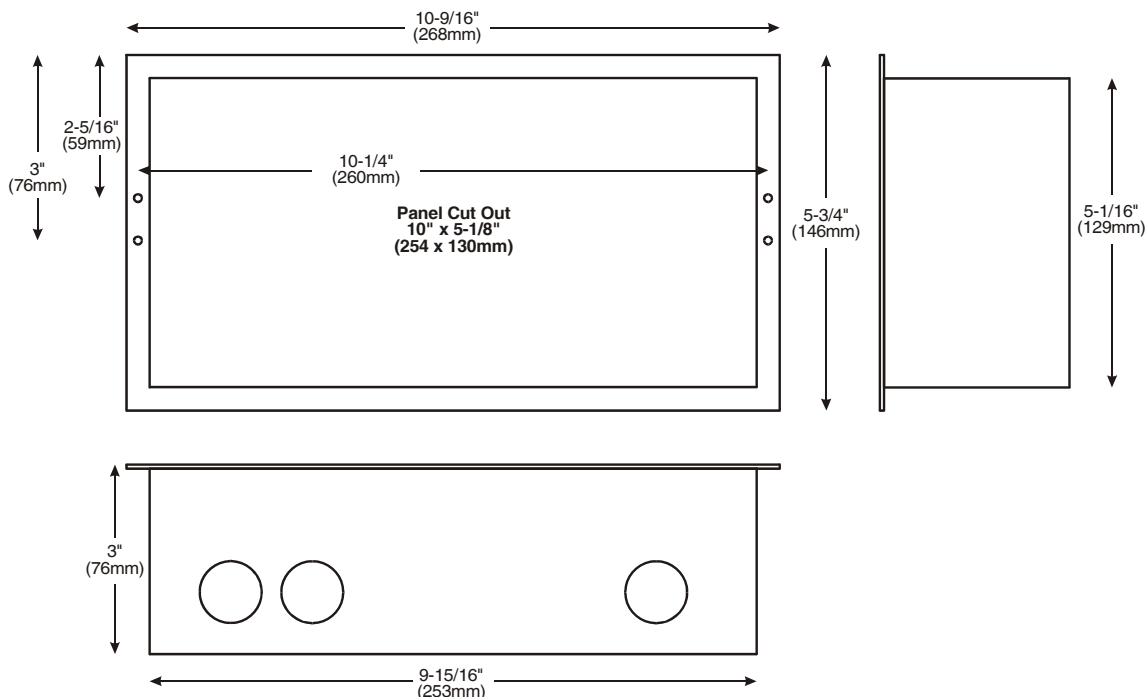
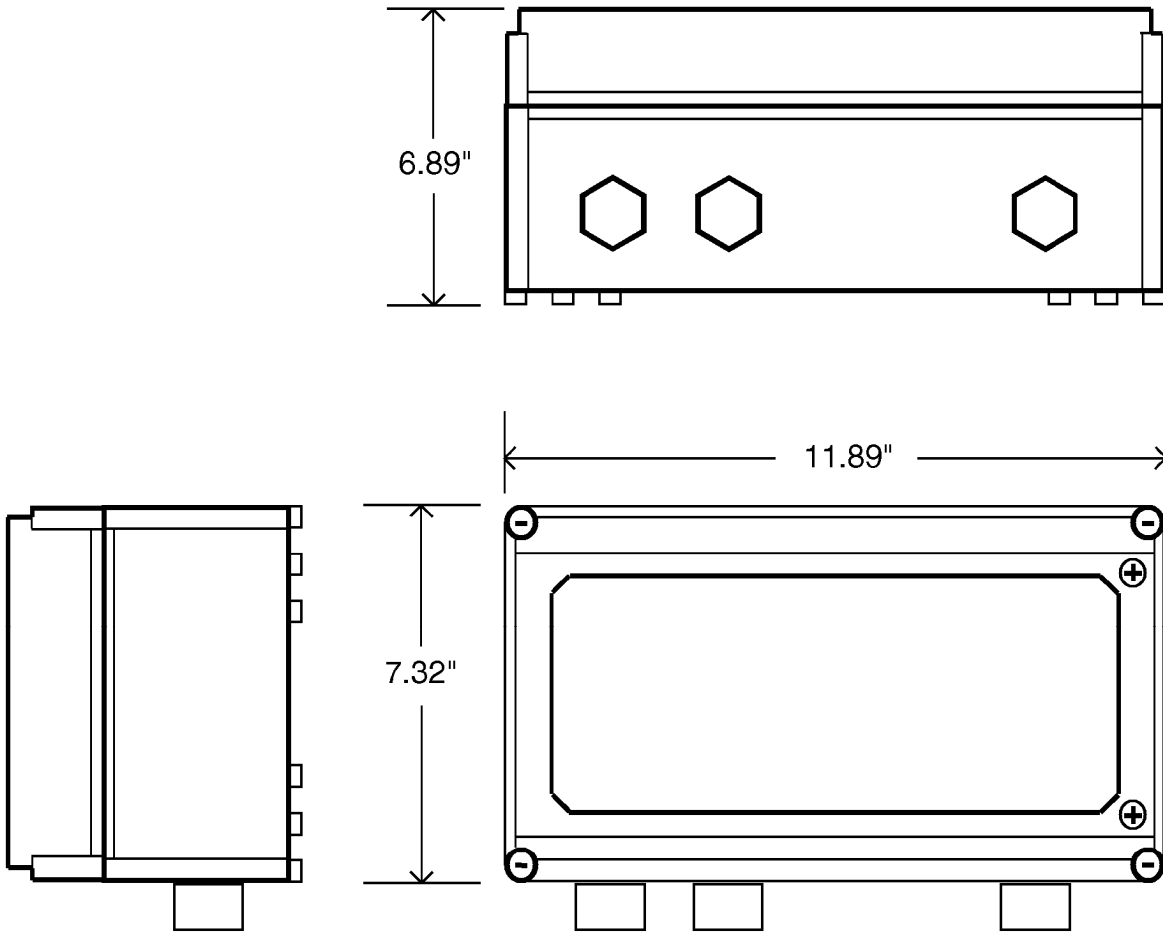
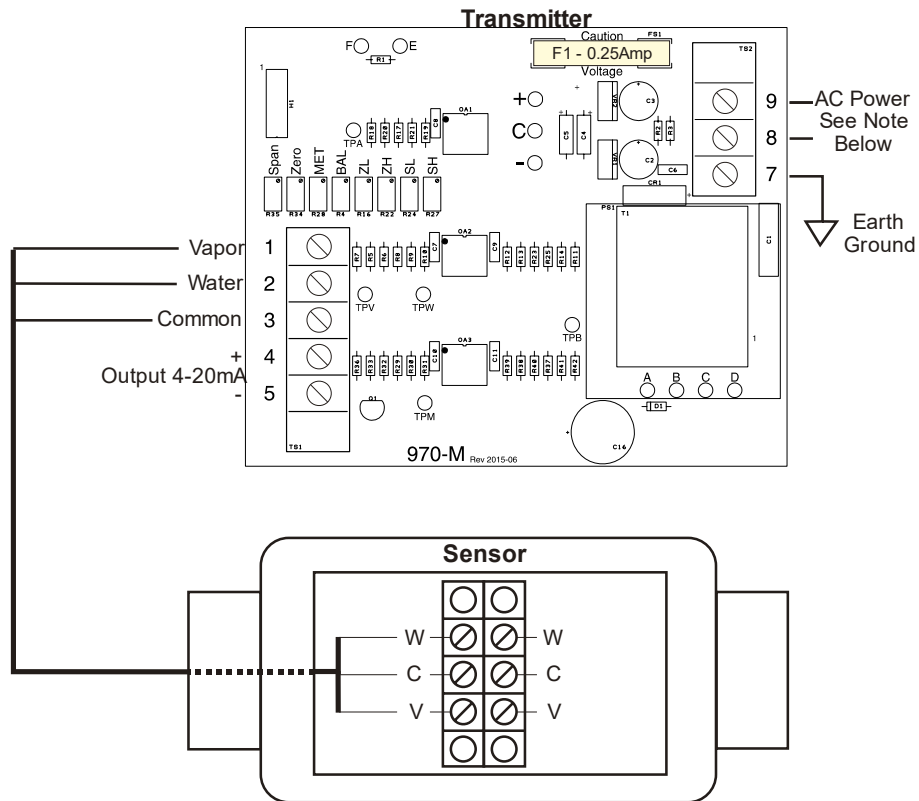

Figure 3: NEMA 4X Enclosure Dimensions



WIRING THE MONITOR

Figure 4: Connecting Measuring Element and Monitor



Transmitter Output: 4-20mA, 600 Ohms Max
Optional Outputs: 0-5 Volts, 0-10 Volts etc.

Note: Before connecting the AC power supply, be sure that jumpers A, B, C, D, E & F are connected as shown below.

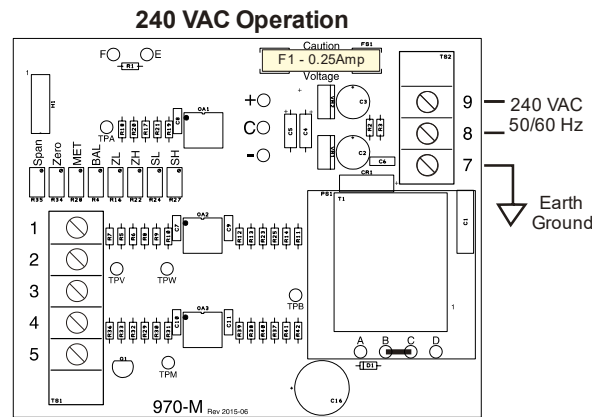
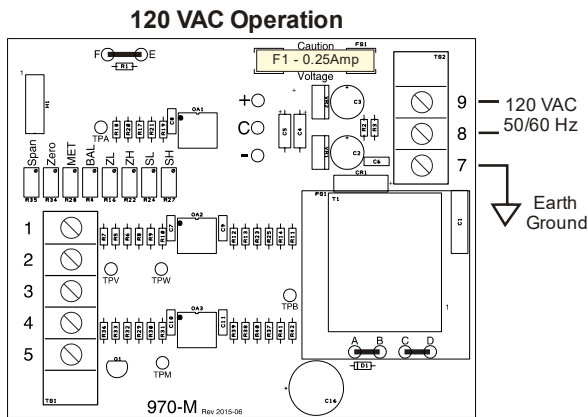

DC Power Connections

For 12-volt or 24-volt DC-powered operation, make all connections as above, except for power connections. Connect **12/24 VDC Positive (+) to terminal 9** and **12/24 VDC Negative (-) to terminal 8**. The jumpers are factory set and do not need adjustment. Be sure that there is a good **earth ground to terminal 7**.

Sensor Connections

Three wires of #22 gauge or larger are required between the measuring element and monitor. Belden cable #8735 is convenient and, although the shielding is superfluous, it is recommended for additional protection against mechanical damage to conductors or insulation. Attach V, W and C terminals to the corresponding ones in the measuring element using the bottom left access hole in the case as shown in Figure 4.

Setting Jumpers for 120VAC or 240VAC

Bring power leads through the bottom right hand hole to terminals 8 and 9. A case ground is at #7. Monitors are furnished wired for 120 VAC power but can be changed to use 240 VAC by cutting the jumpers A to B and C to D and adding a jumper from B to C as shown in Figure 4. Maximum power usage is less than 5 Watts at 50/60 Hz. DC voltages are well regulated, so performance is not affected by voltage or frequency changes of plus or minus 15%.

Output Connections/Settings

For actuating external alarms, recorders, PLCs or I/P transducers, the monitor will supply a 4 to 20 mA over the 0% to 100% supersaturation range. The output resistance must be 600 ohms or less between terminals 4(+) and 5(-) on the terminal strip. If a zero-based signal, say 0 to 16 mA, is needed for an existing recorder, adjust "Zero" on the circuit board. Limited output spans are obtained by setting "Span" on the circuit board. Minor adjustments are easily made during operation when the reading is stable by removing the front panel and setting "Zero" and "Span" until the desired readings are obtained.

Although circuit boards are protected from moisture and fungus attack, it is very desirable that access wiring connections be reasonably well sealed against environmental contaminants to insure long trouble-free operation.

When wiring is complete, replace plug and front panel. The plug is keyed, but be sure it is centered horizontally so all the pins are covered.

START UP

Turn on power to the instrument and set hot water flow to the flash chamber. Adjust dials to the approximate purity of the syrup being boiled. Note that the outer scales are for typical cane syrups and the inner ones for beet syrups. Minor zero adjustment may be required for the particular syrups being boiled but this will be determined on the first few strikes.

Boil a strike manually and watch the monitor indication to be sure that it is approximately correct. When starting, with the pan hot from recent steam-out, the reading should be high. When vacuum is established, the reading should fall slowly as hot syrup is drawn in, and should fall more rapidly when steam is turned on due to the increased vapor velocity. It should

fall below zero if the syrup is considerably undersaturated and then rise slowly as the syrup concentrates.

Maintain reasonably constant vacuum within the 4 to 10" Hg.Abs. range. Have the sugar boiler seed the strike as usual and note the monitor readings as the grain is coming in. If the reading is much above 65% at any time, check syrup with a microscope to try and determine the exact reading at which new grain forms. Or better yet, if the pan was seeded below a 65% reading and grain is growing cleanly, reduce syrup feed so that the oversaturation rises slowly; take frequent microscope checks and at the first indication of fine grain appearing, note the monitor reading. Increase syrup or water feed immediately to reduce oversaturation. After a few such checks, the internal monitor zero can be adjusted so that it reads 65% at the upper limit of the metastable zone for the syrup being boiled. This adjustment is covered in the "Precise Zero Setting" section below.

After grain is established and the massecuite has "pulled together" to a normal 15 - 20% yield, the syrup feed should be set to hold this reasonable boiling consistency. The reading should then slowly fall down toward the 40 to 50% range. It should wander along in this area until the pan is full and feed is cut off. During final brixing, the reading should slowly rise. If it approaches the upper limit, frequent microscope checks should be made for the appearance of false grain and get a further check on the limit of the metastable zone. When boiling syrups of lower purity, it will be found that the limit will be somewhat higher due to the drop in mother liquor purity with increasing crystal yield.

If monitor readings were normal during the first strike, proceed to the "Precise Zero Setting" section below. If not, refer to "Possible Measurement Errors" on page 12 to determine the cause of erratic or very abnormal readings.

PRECISE ZERO SETTING

The purity dials are calibrated for typical beet and cane syrups, but syrup impurities can vary in some localities and a minor zero adjustment may be required. If it is found that, with the dials set for the syrup purity, the meter reads 60% oversaturation when false grain appears, adjust the internal zero to make it read 65%. When the pan is operating and the meter reading is stable at some point, remove front panel (2 screws) and, holding the front to one side, adjust MET on the circuit board clockwise to raise the reading by 5%. Make further checks on succeeding strikes to verify that a reading of 65% indicates the upper limit of the metastable zone.

MET can be brought back to factory calibration as follows: Connect a temporary jumper from Test Point B (TPB) to input terminal 3 (circuit common) and, with it in place, adjust the MET potentiometer to make the meter read exactly 65% oversaturation. (Turning clockwise increases the meter reading). Disconnect the jumper and if the meter does not read exactly 65% when fine grain first appears, adjust the MET setting for the particular syrup being boiled as described under "Precise Zero Setting".

MICROSCOPES

Sugar boilers believe that they can quickly detect the presence of false grain on a proof slide with their naked eye or a simple magnifying glass, but this is not so. The resolving power of the human eye is such that, at even the maximum possible rate of crystal growth, it cannot be detected for several minutes. With a 50 power microscope it becomes visible within a few seconds. An in-pan microscope such as the Lasico Crystalscope is convenient since it allows continuous monitoring of syrup and grain condition to determine the exact point at which new grain forms. But if the syrup in a massecoite is allowed to slowly increase toward the oversaturation limit, frequent examination of proof slides will serve as well. A handheld microscope or any bench microscope of approximately 50 power is adequate if it is located near the pan so that samples may be viewed quickly before they have cooled appreciably. Projection type microscopes with large ground glass screens are of no value for precision sugar boiling because their resolving power for detecting newly formed grain is little better than the naked eye.

BOILING WITH THE 970-M OVERSATURATION MONITOR

With the 970-M Monitor, it is easy to boil strike after strike of high-quality sugars. The continuous indication of oversaturation makes it possible to grow cleaner grain at the maximum possible rate and produce more uniform crystal size which makes for fast purging in the centrifugal. Some best practice rules of sugar boiling are reviewed here briefly. For more detailed reasons behind them, see the sugar articles at www.zieglerassociates.com/articles.htm.

The first step is the establishment of good seed crystals on which sugar can be deposited. The best results have been obtained by seeding an oversaturated syrup with the proper number of clean nuclei prepared by grinding sugar in a media such as anhydrous isopropyl alcohol. These slurries are prepared from a mixture of alcohol and sugar in about 2/1 volumetric ratio, ground for 10 to 15 hours in laboratory ball mills or in patented mills such as the Ditmar or Sweco for shorter times. By fixing the grinding time, standardized slurries containing a predictable number of nuclei per ml. can be produced; around 2.5×10^9 particles per ml. Relatively small amounts are needed to full seed pans, ranging from 15 ml for raw sugar with large grain to a few hundred ml for pans producing fine grain finished beet or cane sugar.

Dry hammer-milled sugar is inferior in that many of the particles stick together in storage; the number of individual particles changes with time so the required amount is unpredictable. Also the final sugar will contain more conglomerate grain.

So-called "shock seeding" by introducing a little sugar into syrup concentrated into the labile zone should be avoided because it appears impossible to control the number of nuclei formed spontaneously and invariably, too many are produced which conglomerate and form ball grain, representing inferior sugar.

The objective in good sugar boiling is to introduce the required quantity of clean individual nuclei and grow them without further nucleation to mature clean grain. This is not as easy as it sounds, especially in syrups of higher purity because crystals tend to stick together to form

conglomerate grain. The tendency increases with oversaturation, with purity, and with the average distance between adjacent grain. It is decreased by increased massecuite circulation. In a given pan, the only variable that can be manipulated is oversaturation. Conglomeration must be avoided as far as possible to produce sugar with low color but minimum washing. It is a fact that most conglomeration occurs during the first few minutes after seeding when the crystals are around 0.001" to 0.002" in size. Holding lower oversaturation during this period invariably produces cleaner final sugar. Two methods can be used: The easiest one is to seed the concentrating syrup in the 40% to 50% oversaturation range, take a microscope check to be sure that the required crop has been established, and start a normal flow of syrup feed to hold the oversaturation constant at this level. After 10 to 15 minutes, the feed may be reduced, allowing the concentration to rise to something short of the 65% oversaturation limit. Alternatively, the syrup may be taken up toward the 65% limit, the pan seeded, and a copious "drink" of syrup or water added to bring the oversaturation down quickly into the 40% to 50% range during the early stage of crystal growth.

There is less tendency for crystals to conglomerate in syrups of lower purity, but even in these syrups, better grain will be formed if oversaturation is held somewhat lower during the first several minutes after seeding.

BRINGING TOGETHER

Once a good clean crystal crop is established, it is desirable to reduce syrup feed and allow the oversaturation to rise into the 60 to 65% range for rapid grain growth. As crystal yield increases, the massecuite consistency will increase and after a time, will reach a good boiling consistency with 15% to 20% crystals on total solids. It is during this phase of sugar boiling that many otherwise excellent strikes are irreparably spoiled. A sugar boiler likes to tighten a strike as soon as possible because a tight strike is a safe one; there is plenty of crystal surface to absorb all the sugar that can be made available by boiling and he can relax and just feed to keep the massecuite consistency within bounds. But, if the tightening process is done too rapidly before sufficient crystal area has been produced, the syrup can easily reach excessive levels of oversaturation and a second crop of crystals will form. They can only be melted out by adding enough water to make the syrup undersaturated and waiting until they completely dissolve, but this is costly in terms of time and steam. If the strike is continued, the crystal size will be mixed and produce an inferior massecuite.

By watching the oversaturation monitor and keeping it high, but on the safe side of the 65% limit, tightening can be accomplished in minimum time without additional grain formation and an excellent strike is on its way. When boiling consistency is reached, it is maintained by regulating feed until the pan is full, at which time, the oversaturation will have slowly fallen to the 40 or 50% level.

FINAL TIGHTENING

When maximum massecuite level is reached and syrup feed is shut off, all the water being evaporated must come from the mother liquor syrup so the oversaturation will rise slowly. It must not be allowed to exceed a safe limit or some fine grain will form and, although their presence may not hinder centrifugal separation too much, the pan yield will be reduced; most of the fine crystals will pass through the centrifugal screens and be lost in the molasses and

some will adhere to the good crystals and can cause a dust problem when dried. During final brining, it is most desirable to deposit the available sugar on the existing crystals; this is the time of greatest sugar production in the pan cycle so a few extra minutes taken to brin up are well spent.

If it appears that oversaturation will reach an unsafe limit during this critical stage, then reduce the evaporating by cutting steam flow or introducing some water feed. The latter is preferable as it maintains circulation.

Increasing crystal yield during final tightening does not appreciably affect the mother liquor purity in high-grade strikes. But in those of lower purity, it is necessary to use some judgment in determining the safe limit of syrup concentration. Refinery syrups at 99 purity would only drop to 98 purity at a final yield of 50% solids in crystal form. If the monitor zero had been correctly set during the early stages when crystal yield was low, the oversaturation should not go above 65%.

Before dropping low grade strikes, the mother liquor purity will have fallen below that of the massecuite but generally in these strikes the yield is not high at pan drop; most of the yield will come out in the crystallizers. For example, a 65 purity cane C strike might only have 20% yield when dropped so the mother liquor would be 54 purity. By setting the monitor zero dial over this range, it is seen to make 12% oversaturation change. So leaving zero set at 65 purity the indication just before dropping could be allowed to go into the red zone but not over 77% oversaturation. A typical beet white strike with 93 purity standard liquor will have around 40% crystal yield when dropped and it will increase in the mixer to around 55% or better. But when dropped at the end of brining the mother liquor will be around 88 purity. The five point drop from massecuite purity amounts to about 8% increase in oversaturation. It has been verified many times that in the final moments before dropping, fine grain will begin to appear if the reading gets above 73% oversaturation.

The maximum increase in oversaturation reading that can be tolerated during final tightening can be easily determined by frequent microscope examinations of the first few strikes boiled on a particular syrup. Once it is determined, the sugar boiler need only stay below the limit during that period. Actually, if good boiling has been done during preceding portions of the cycle, the oversaturation will seldom rise to an unsafe level during the final stage; the crystal area is increasing rapidly and the boiling rate is falling as the consistency increases so it will generally be observed that the reading rises slowly, levels off and begins to fall before the end of the strike.

The crystallization rate decreases with syrup purity even at the same oversaturation. On lower grade strikes, high oversaturations are held during a large part of the cycle. When feed syrups are quite concentrated, the pan may fill before crystals have had time to grow to proper size for good centrifugal separation. It is wise to prolong the pan cycle under these circumstances by reducing syrup feed and supplementing with some water feed to maintain oversaturation at a high but safe value. It is better to boil rapidly to keep good massecuite circulation and feed water than to reduce steam flow.

CRYSTAL YIELD

Crystal yield in a final massecuite may be expressed in various ways, but the most practical seems to be as the percent of crystals on the total solids present. In the laboratory it can be calculated from just two measurements: massecuite and spun syrup purities. Yield is the purity of the massecuite minus the purity of the syrup, divided by the purity of the sugar (nominally 100 in higher grade strikes) minus the purity of the syrup; all times 100. A massecuite purity of 90 and a syrup of 80 indicates a crystal yield of 50%.

Strikes of clean, uniform crystals can be carried to far higher yields than those of mixed size grain not well formed. Good boiling techniques made possible by the 970-M Oversaturation Monitor can produce higher yields on all strikes. In higher purity syrups, 60% yields are readily attainable and 45% yields are not uncommon crystallizer strikes.

Boil clean grain and concentrate to the highest possible consistency that can be handled out of the pan and into centrifugals. A few good strikes can completely unload a full pan floor, leaving time to do even better work. With less low purity material to boil, the amount of seed used in the low end can be reduced to produce larger grain for easier purging and better molasses exhaustion. False grain formed at any time in any strike detracts from pan floor performance and it only forms when safe oversaturation limits are exceeded.

Properly installed on a good pan, the 970-M Oversaturation Monitor will measure the most important variable in sugar boiling, making it possible to boil more and better sugar in less time. But the mere presence of this most valuable indication does not guarantee excellent results. To achieve precision sugar boiling, intelligent use of the measurement must be made. It is very easy to teach new operator to do consistently good work with a monitor-equipped pan; it is sometimes more difficult to convince more “experienced” operators that they can do better work by using the guidance provided by the monitor. In any event, with either old or new operators, it is generally desirable to periodically supervise their work to see that they do not develop poor boiling habits or become careless about observing best practices on every strike.

POSSIBLE MEASUREMENT ERRORS

The 970-M Oversaturation Monitor measures the temperature of vapor leaving the massecuite surface. Since the vapor is superheated, certain problems can occur in obtaining an accurate and precise temperature measurement. Precise temperature is important because full scale on the monitor represents only 6 to 9°C change, depending on purity settings. Boiling point elevation is a sound method for determining oversaturation, once all the sources of error are eliminated. This section discusses possible pan deficiencies and suggests ways to eliminate them.

Even small additions to or subtractions from pan vapor temperature between the massecuite surface and the point of measurement will cause intolerable errors. For example, a 3” steam out valve open only 0.005” will leak enough to raise pan vapor 1°C and increase the reading about 15%. As little as 150 ml/minute of water leakage into the vapor stream ahead of the measuring point can drop it a like amount.

UPSCALE ERRORS will be caused if pan heating surface venting of non-condensibles is carried to the pan itself. They should be vented to atmosphere or to some point beyond the measuring bulbs. Leaking steam-out valves must be replaced or double-valved. Even live steam entering the pan below the massecuite surface will not be absorbed as it bubbles upward, although the error will diminish with increasing massecuite level in the pan. A leaking calandria tube or leaking discharge valve steam out connection has been found responsible for errors of this nature.

On coil pans, check all steam supply valves for leakage because a hot coil or coils above the massecuite surface will add heat to the ascending vapor and the resulting upscale error will not be corrected until that coil is covered. Check the condensate system of such pans for the possibility of backflow through the traps to unused coils. A small vent valve on each coil can be opened to check for leakage from either the supply or condensate and to locate the bad coils.

An upscale error will result from either low flow or low temperature of water to the reference bulb. Be sure that adequate quantity of water is being delivered to the flash chamber at a temperature high enough to flash at the prevailing pan vacuum. A good rule is to have it at least as hot as the massecuite in the pan which will be 8 to 15°C higher than the flashing temperature. Do not worry about having the supply water too hot since it can never flash to dryness at any attainable pan vacuum. As previously noted, a persistently high oversaturation will be indicated if air is leaking into the line supplying water to the reference bulb between the metering valve and the measuring element.

A temporary upscale error is usually present when a new strike is started soon after steaming out a pan due to stored heat in pan walls and entrainment separator. Actually little heat is added to the vapor by pan walls due to the relatively low vapor velocity, but some is picked up as it is accelerated in the separator. In steel pans, this represents little problem as the surfaces quickly fall to vapor temperature after boiling starts. But on older pans with heavy cast iron domes and separators, it can retard the temperature drop to equilibrium and it becomes more desirable to locate the element near the entrance end of the separator where the vapor first reaches an adequate velocity, points A or B in Figure 5. Alternatively, a short spray of water can be introduced when boiling starts and the lower temperature vapor will quickly cool the internal pan surfaces below the boiling temperature of the concentrating syrup.

Figure 5: Locating the Sensor Element on Pans with Cast Iron Domes and Separators

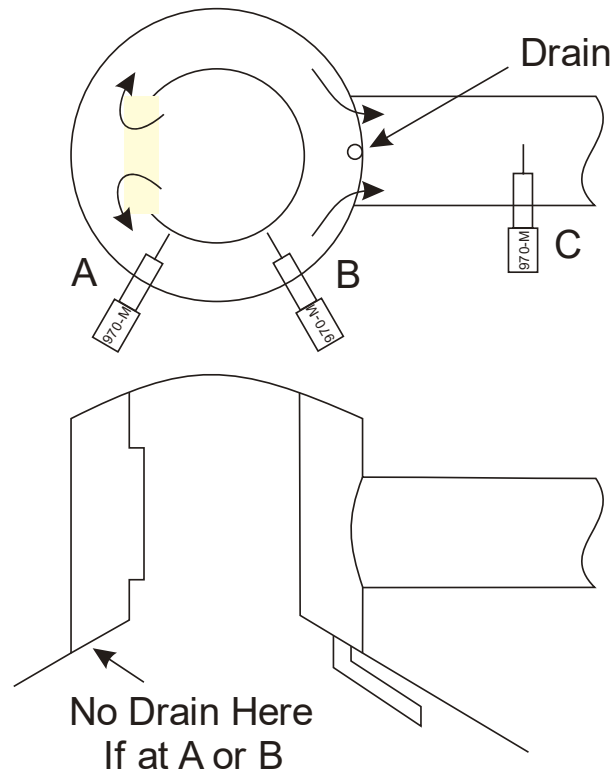

DOWNSCALE ERRORS are generally caused by water addition to the vapor stream before it reaches the vapor bulb. Even small quantities of water can appreciably desuperheat the vapor and destroy monitor accuracy and reliability. Here are some of the places where this can occur, with suggestive corrective measures:

Overhead spray systems for washing pans are a common source of trouble. If any water remains in the spray header, it can be heated by the superheated vapor during the strike to its boiling point and periodically spurt out to mix with the vapor. Each time this happens, the oversaturation reading will drop suddenly, often below zero, and slowly recover toward a correct reading. A hole should be drilled at the lowest point of such a spray system, 3/8" or so in order that the header will drain completely before the next strike is started. Needless to say, wash water valves should be checked to be sure that they are leak-free.

Steam out valves should be located in a horizontal run near the pan to eliminate the possibility of vapor condensing in a riser outside the pan and accumulating to a level that would be heated to the boiling point and spurt into the pan vapor.

Minor water leaks at pan walls such as window wash sprays do not affect monitor readings as they quickly mix with boiling masecuite. Only those that can be shattered into the vapor stream ahead of the measuring point cause trouble.

Pans equipped with overhead drive circulators present a problem if the shaft packing is water-lubricated. A small flow of water will find its way down the shaft and mix safely with the boiling masecuite, but if the packing is not well maintained, increasing water leakage will flip off the rotating shaft and couplings and be picked up by the vapor. In this case, it is better to meter the

flow of water to the packing by means of a needle valve or rotameter and keep it low enough to prevent vapor cooling.

As noted earlier, excessive water flow or reference chamber temperature might make a small downscale error due to friction drop through the exit window, but this is unlikely if the connection is made with 1/4" OD tubing. This is easily checked by shutting off the water flow for a few seconds to see if there is any appreciable change in monitor reading.

Occasionally a barometric condenser with poor internal baffles allows water to splash back into the entering vapor line at high water flow rates. That water may find its way back into the pan separator, especially if the vapor line slopes toward the pan. If it mixes with vapor ahead of a bulb installed at point C, it will cause erratic downscale errors (see Figure 5). This situation can sometimes be improved by moving the element to point A or B, but eventually the condenser design should be improved. When condensers are located below the pan vapor outlet, the measuring element should be located in the vertical run so that the reference water definitely goes to the condenser.

Many different types of entrainment separators are used and it is not possible to cover all their design frailties in this manual, but here are a few typical problems. Vapor leaving the boiling surface will always contain a mist of fine syrup droplets, fine enough to be carried upward with the vapor stream. In the separator, the velocity is increased and the droplets made to impinge on surfaces to coalesce so that they can be removed from the main vapor stream. Separation is not enough and designers often provide inadequate means for returning the entrainment to a place of safety. In the typical centrifugal separator of Figure 5, the best method seems to be to run a line from the lowest point of the separator and seal it in a melter or tank downstairs. Most pans, however, only have a hole or a pipe in the deck through which the syrup can run back to the pan. Rivulets of syrup will indeed run down a hole of adequate size but against a flow of vapor coming up through the hole; the upward flow caused by the drop across the separator, often several inches of water. This upward flow will toss drops of syrup back up into the vapor stream. Obviously, any dilution of the syrup at this point will act to desuperheat the rising vapor before it reaches the vapor bulb.

The reference water flashing in the measuring element must not be allowed to mix and be picked up in the entrainment separator ahead of the vapor bulb. When the condenser is above the pan outlet, the vapor velocity will not be high enough to lift it to the condenser. One solution is to move the measuring element from C to A or B (Figure 5) provided that the only separator drains are beyond these points. With radial separators, the measuring element almost has to be in the vapor line (Point C) because that is the first point of reasonably high velocity. A more universal solution is to locate the element in the vapor line and prevent any possibility of water from condenser splash or reference water flash from finding its way back to the separator by installing a low dam in the vapor line (Figure 6) and providing a drain line to the condenser or its barometric leg line. Measurement may then be made at points D or E.

Figure 6: Installing a Low Dam in the Vapor Line

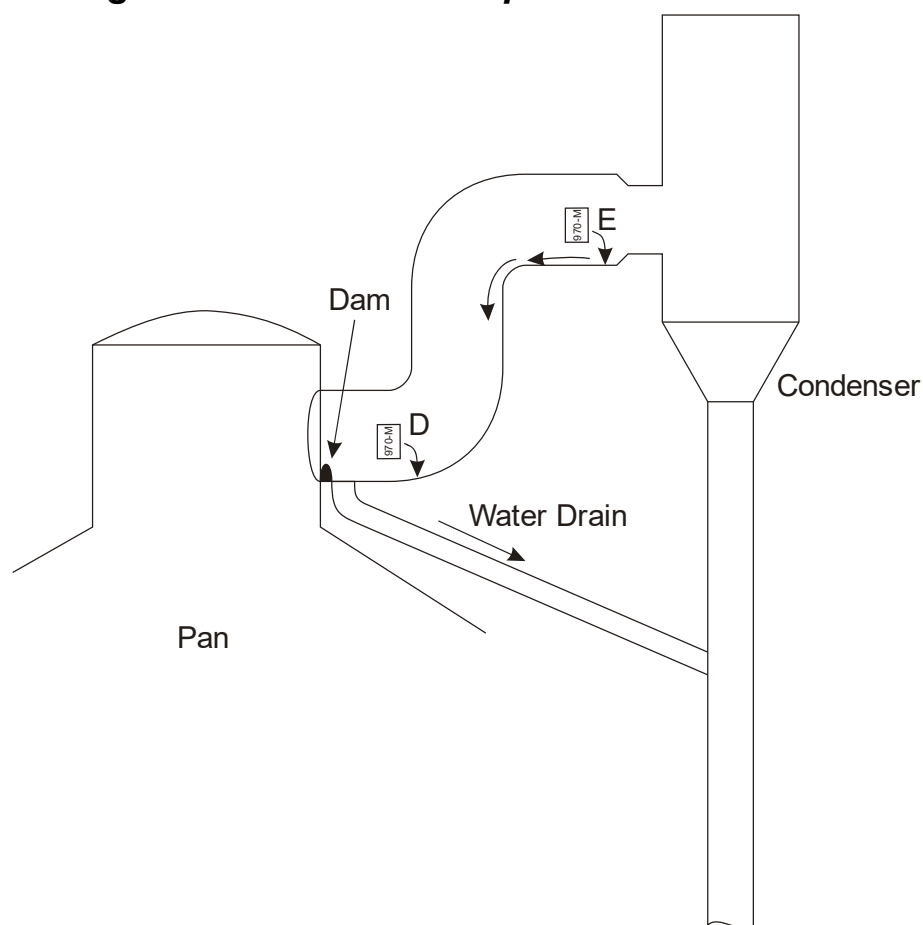

DYNAMIC ERRORS in temperature measurement are always present and are caused by the inability of any measuring element to follow rapid temperature variations. The monitor vapor bulb is designed for the minimum lag consistent with adequate mechanical strength but still has a time constant around 20 seconds in normal vapor velocities. The water bulb responds very quickly due to the higher rate of heat transfer. So any sudden change in pan vacuum will cause a temporary error in oversaturation reading. Precision sugar boiling cannot tolerate abrupt variations, at least when syrups are being held near the upper safe limit of oversaturation, because any increase in vacuum can easily carry them into the danger zone (above 65%). Reasonably good regulation of pan vacuum is therefore highly recommended.

A sudden increase in vacuum will increase evaporation at the massecuite surface, lowering the syrup temperature and thereby increasing the actual oversaturation. The monitor will read high because of the difference in response time of the two bulbs. The reading will fall back to the correct value shortly, but monitor readings should be ignored during such sudden transient conditions. When pans are regulated manually, steam flow and condenser water flow should be changed gradually so that pan vacuum remains relatively constant or drifts gradually to prevent getting erratic oversaturation readings especially during critical stages of a strike. Under automatic vacuum or absolute pressure control, it is better to reduce controller gain or sensitivity so that there will be no periodic oscillation in vacuum because they would create corresponding varying indications on the monitor. It is better to allow the control to float around the desired value and get proper readings of oversaturation.

Factories with central condenser systems should cut in empty pans very gradually so as to minimize vacuum disturbances on operating pans.

The monitor circuitry is designed to compensate for boiling pressures between 4" and 10" Hg. Abs (10 to 25 cm Hg. Abs) Outside of these limits, the oversaturation reading will be on the high side for the actual conditions and, although a corrective zero adjustment can be made with "MET" compensation will only be good over a limited range of vacuums.

Troubleshooting of 970-M Oversaturation Monitor installations centers around pan problems. Sometimes these problems can be quite difficult to locate by observing only the monitor indications, since oversaturation is a differential temperature measurement. One can use an accurate ohmmeter to measure vapor and reference water temperatures separately, thus isolating the measurement in error. Calculate the temperature of each bulb using the following equation: $T(^{\circ}\text{C}) = (\text{R}(\text{ohm}) - 585)/3.3$

FEED DISTRIBUTION

In order for the 970-M Oversaturation Monitor to read the maximum value in a massecuite, it is essential that the maximum value be at the upper surface. As heated material boils and moves toward the surface, its temperature falls due to the lower hydrostatic head and it reaches a maximum oversaturation at the surface; its boiling point then corresponds to the vapor pressure, and this is the temperature measured by the monitor vapor bulb. Syrup or water feed introduced into the pan at a low level must mix thoroughly with the massecuite before it reaches the surface. If feed does not mix well, it can float to the surface, boil there, and naturally the monitor will indicate its concentration rather than that of the massecuite. This can be especially apparent on strikes started from a massecuite "footing" if diluting syrup is introduced to reduce its viscosity and boiling started with the non-homogeneous mixture. A proof sample will show a heavy massecuite, but the monitor will indicate the low syrup concentration at the surface.

Good feed distribution is essential in all pans. It should be introduced at several points under the calandria about halfway between the center well and the outside wall whether or not a mechanical circulator is used. This gives it the best chance to mix as it rises through the tubes. Under no circumstances should the feed enter the center well even with mechanical circulation. Excessive feed flow at any time during a strike should be avoided to reduce the possibility of poor mixing; a steady flow is better.

TECHNICAL INFORMATION

ELECTRICAL TESTS

The monitor electronics are very reliable and unlikely to have problems. However, the power supply voltage can be measured across terminals C and + (+15 volts) and across C and - (-15 volts). Page 19-21 show the circuit board layout and the circuit diagrams.

Measuring element damage or wiring errors can be located by a few simple tests. When the element is at normal pan operating temperature, disconnect the V and W wires from terminals 1 and 2 and measure the resistance of each bulb to common terminal 3. Both should measure around 800 ohms. If the temperatures are known, the resistance should equal $585 + 3.3T$ where T is the temperature in °C; i.e. 832 ohms at 75°C.

In operation with the measuring element connected, the voltage drop between terminals 1 and 3 will be close to 1.85 volts and 2.0 volts from 2 to 3. The regulated power supply voltages for the amplifier appear on the two test points marked + and - in the upper center of the circuit board. Relative to terminal 3 (or Test Point C), they should remain very close to +15 and -15 volts. Supply for the output transistor will be on terminal 4 and should be around 30 volts.

The 970-M Monitor may be checked on the bench without the measuring element as follows: Put a jumper between terminals 1 and 3 and connect a 60 ohm resistor between terminals 2 and 3. With both purity dials set at 100P, the meter should read close to 100% oversaturation. With both dials set at 50P on the outer (cane syrup) scale, the reading will be near 5% oversaturation.

SENSOR/MEASURING ELEMENT

Sensor Dimensions

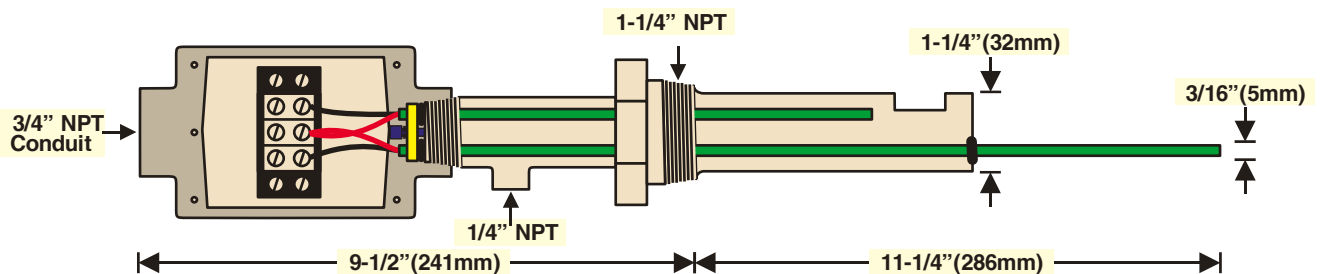

Sensor Parts

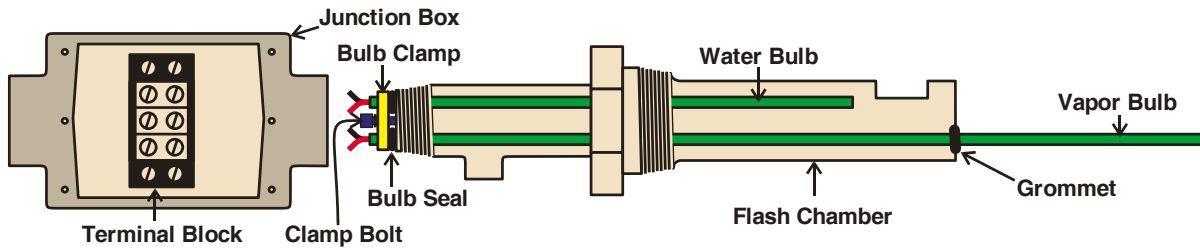

ELECTRONIC TRANSMITTER

Circuit Board Component Layout

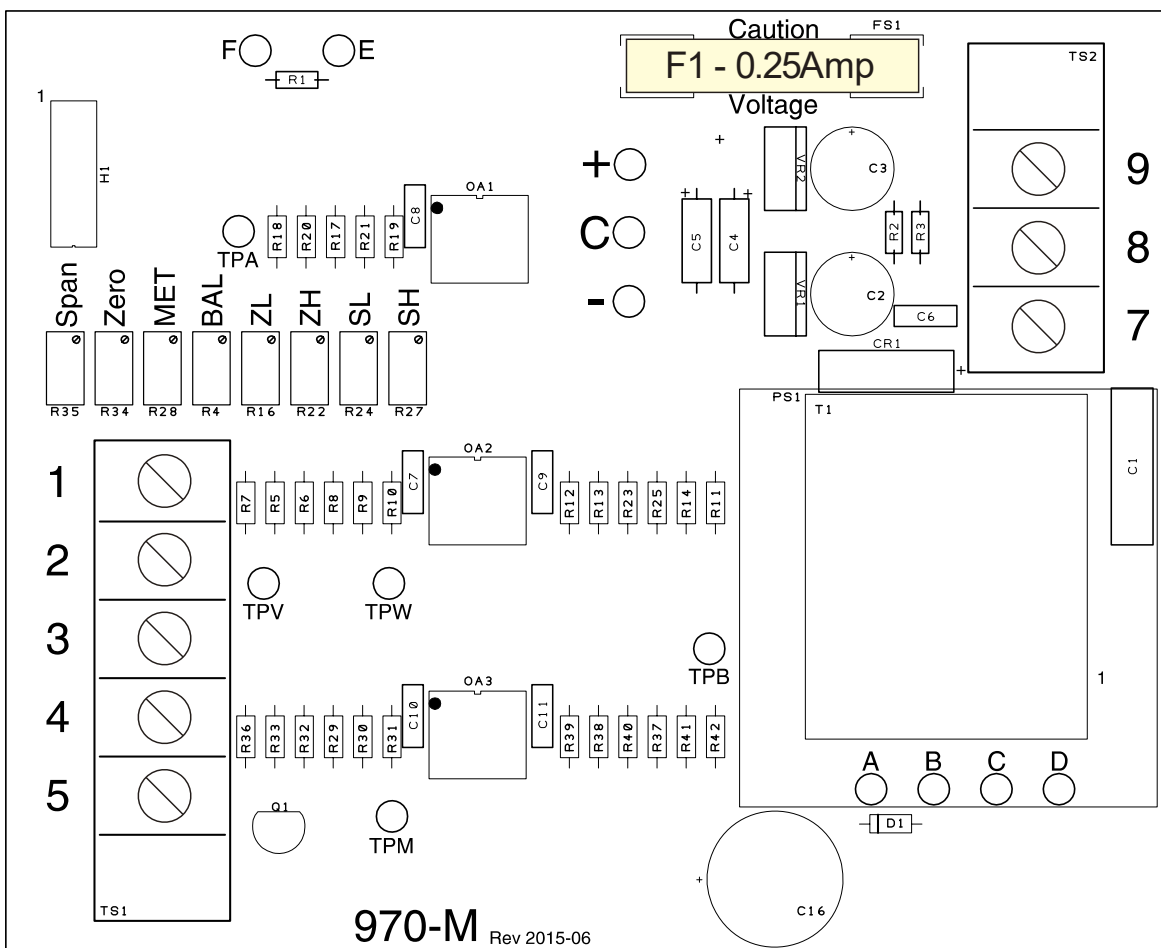

Circuit Diagram (AC Power)

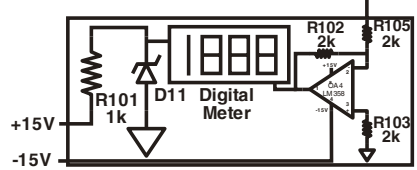
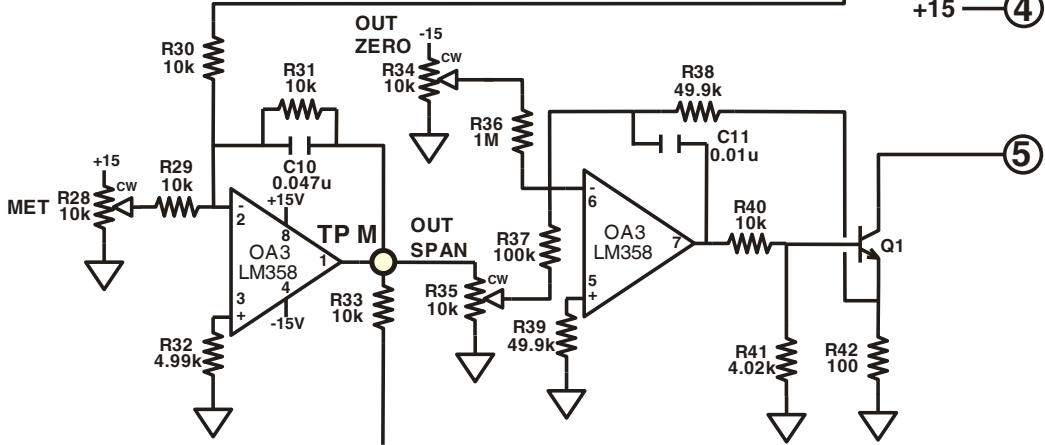
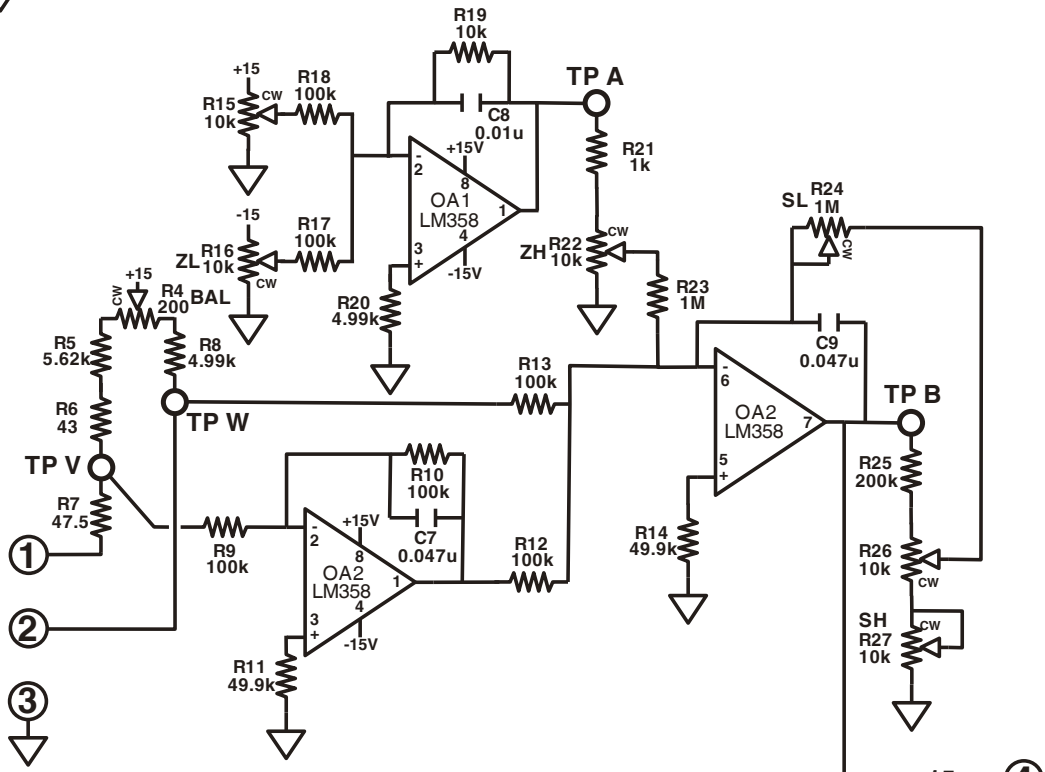
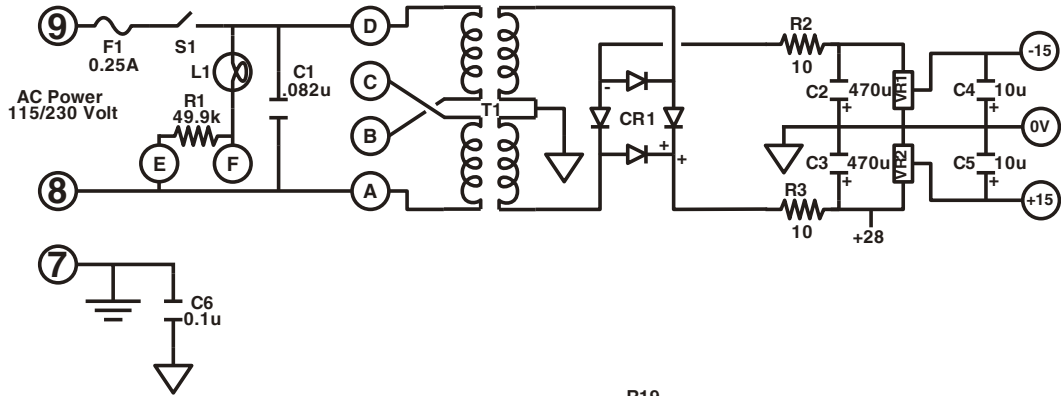

Circuit Diagram (DC Power)

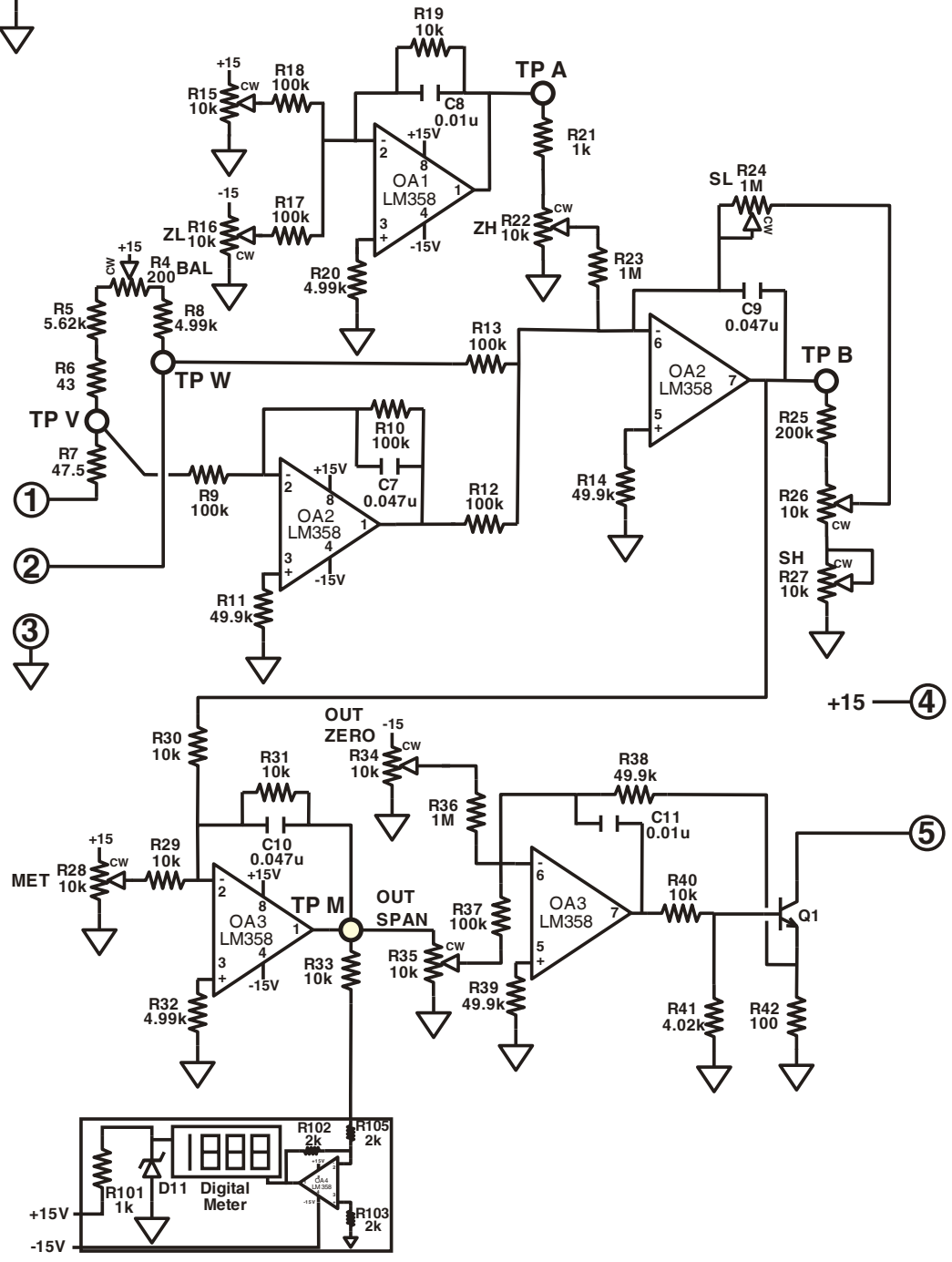
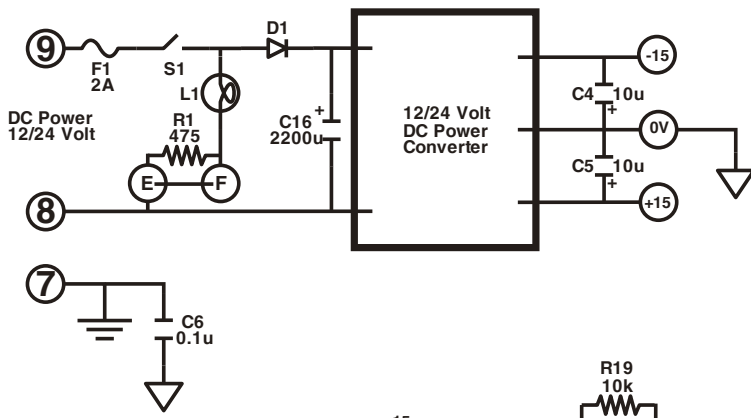

WARRANTY

Ziegler & Associates' products are warranted to be free from defects in material and workmanship for a period of one (1) year from the date of shipment. The final determination as to whether the product has failed due to defects in materials or workmanship rests solely with Ziegler & Associates. Products that have been proven to be defective in workmanship or materials will be repaired or replaced at Ziegler & Associates' facility at no charge to the buyer. Defective instruments must be returned to Ziegler & Associates freight prepaid. **THERE ARE NO IMPLIED WARRANTIES OF MERCHANTABILITY OR OF FITNESS FOR A PARTICULAR PURPOSE GIVEN IN CONNECTION WITH THE SALE OF ANY ZIEGLER & ASSOCIATES PRODUCT(S).** In no event shall Ziegler & Associates be liable for consequential, incidental or special damages. The buyer's sole and exclusive remedy and the limit of Ziegler & Associates' liability for any loss whatsoever, shall not exceed the purchase price paid by the purchaser for the product or equipment to which a claim is made.